

# Plasma Jet PFW10

## Single fixed Jet



### For pre-treatment and cleaning of::

- films and three-dimensional parts
- plastic, metal and glass

The treatment is made by a potential-free plasma jet that delivers our Openair®-Plasma. The plasma is generated by an atmospheric pressure high-voltage discharge in the jet's reaction chamber, forming a discharge that exits the jet nozzle at high velocity onto the surface of the part to be treated. The entire high voltage is kept inside plasma jet.

The treatment is potential-free, so the part is not exposed to high voltage. As well, both plastics and metals can be effectively pre-treated with the same system.

The treatment is made very effective by a combination of chemical and physical effects. There is both removal of organic contaminants and an improvement of surface wettability through modification of areas on the surface.

The preliminary treatment is done very accurate to the outline. This plasma jet is mainly used when surface pre-treatment requires high process speed, high energy, or if only a limited area of the part (e.g. groove-bonding) is to be pre-treated.

### Applications:

- Preliminary treatment of the bonding groove on PP-headlight assemblies, immediately before the application of adhesive in the bonding channel.
- Inline preliminary treatment in bottle labelling, enabling substitution of hot-melt and dispersions with use of wet bonding systems.
- Purpose-built configurations with up to ten jets for treating EPDM-profiles or universal laminating.
- Multi-jet Array tool for preliminary treatment of aluminium profiles, as substitute for etching and chromic acid etching.
- Preliminary treatment on a fibre with a linear speed of 600 m/min.

*The working process window is determined by jet distance, treatment width and process speed. They are strongly dependent from the way the plasma exits the jet. The Plasma jet can delivered with different jet nozzles according to the applications.*

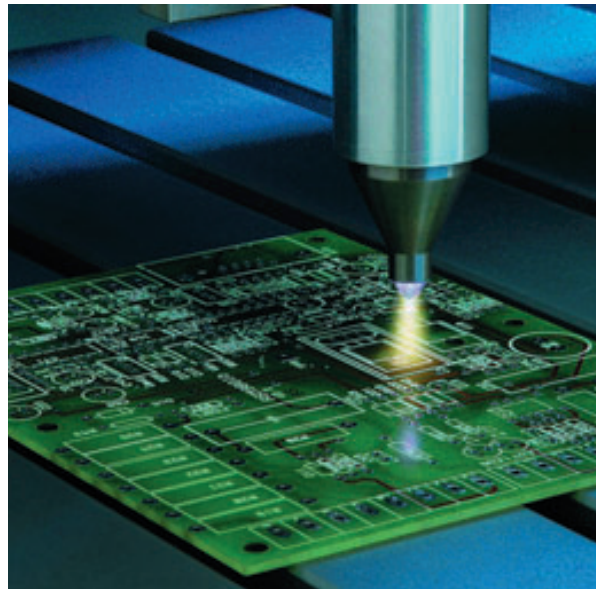

## Technical data:

### Minimal wear parts in the system.

Connection to a motion system is possible via a mounting plate. There is the option of adding a light control unit for on-line process control.

Safety circuit and necessary pollutant vacuum cleaning, if wanted, can be planned by the customer.

### Technical data:

Working frequency	16-20 kHz
Electrode voltage / Plasma performance	5–10kV / 500 ... 1000 W
Plasma generator, high voltage unit	at least FG3001 with 1 kW; HTR12
Connecting cable Plasma jet	EMV-protected pipe: D= 28 mm; L <sub>max</sub> = 2,5 m to high voltage unit
Treatment width	Re substance, jet used and distance - 4 to 20 mm
Relative Speed to Surface (Treatment Speed)	Up to 900 m/min
Effective Treatment Distance between Jet Front and Substrate	Between 5 and 25 mm
Weight	< 1 kg
Working gas	Oil and water free Compressed Air (ca.1,2 m³/h)

### Schematic (technical changes reserved):

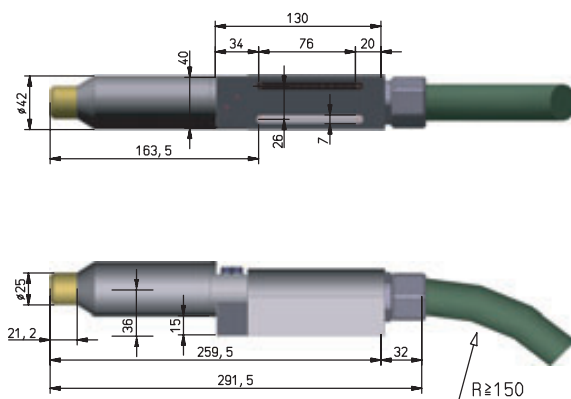

Please refer to our Data sheet "Security Information" for use of our Openair®-Plasmatreat System.

### Different types of Plasma Jet Heads:

